

# Wet Scrubber O&M Issues

Ron Richard  
Senior Consultant  
RE Consulting

# Ball Mills

# Limestone Fineness

- Some of the FGD vendors have stated that one of the biggest causes of performance issues they find is improper limestone fineness in the limestone slurry feed to the absorber tower.

## Effect of Limestone Grind

(Different Shaped Symbols Represent Different Limestone Tested)

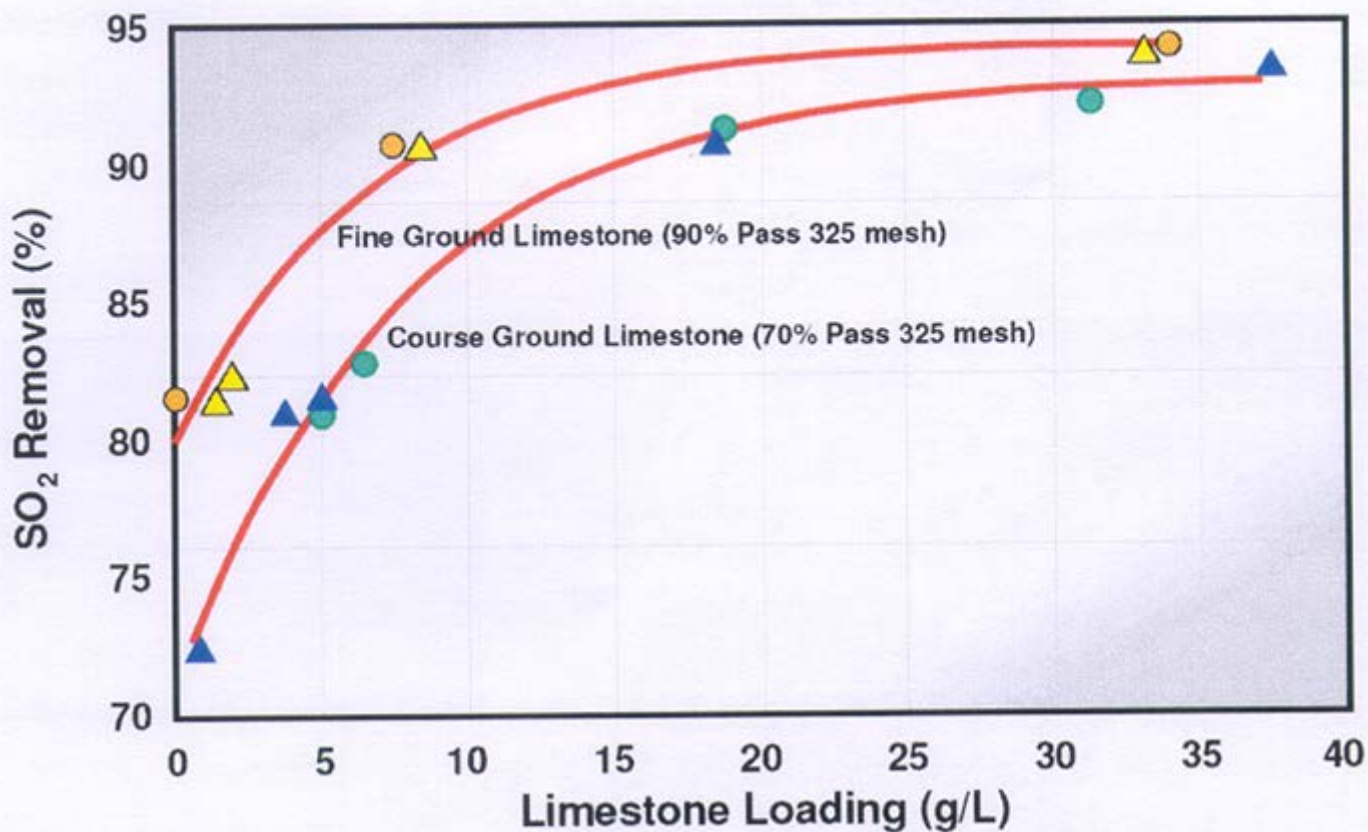

Source: URS

# There Are Two Things To Check First

- Do the ball mill motor amps indicate that the mill has a full ball charge.

# Normal Ball Level

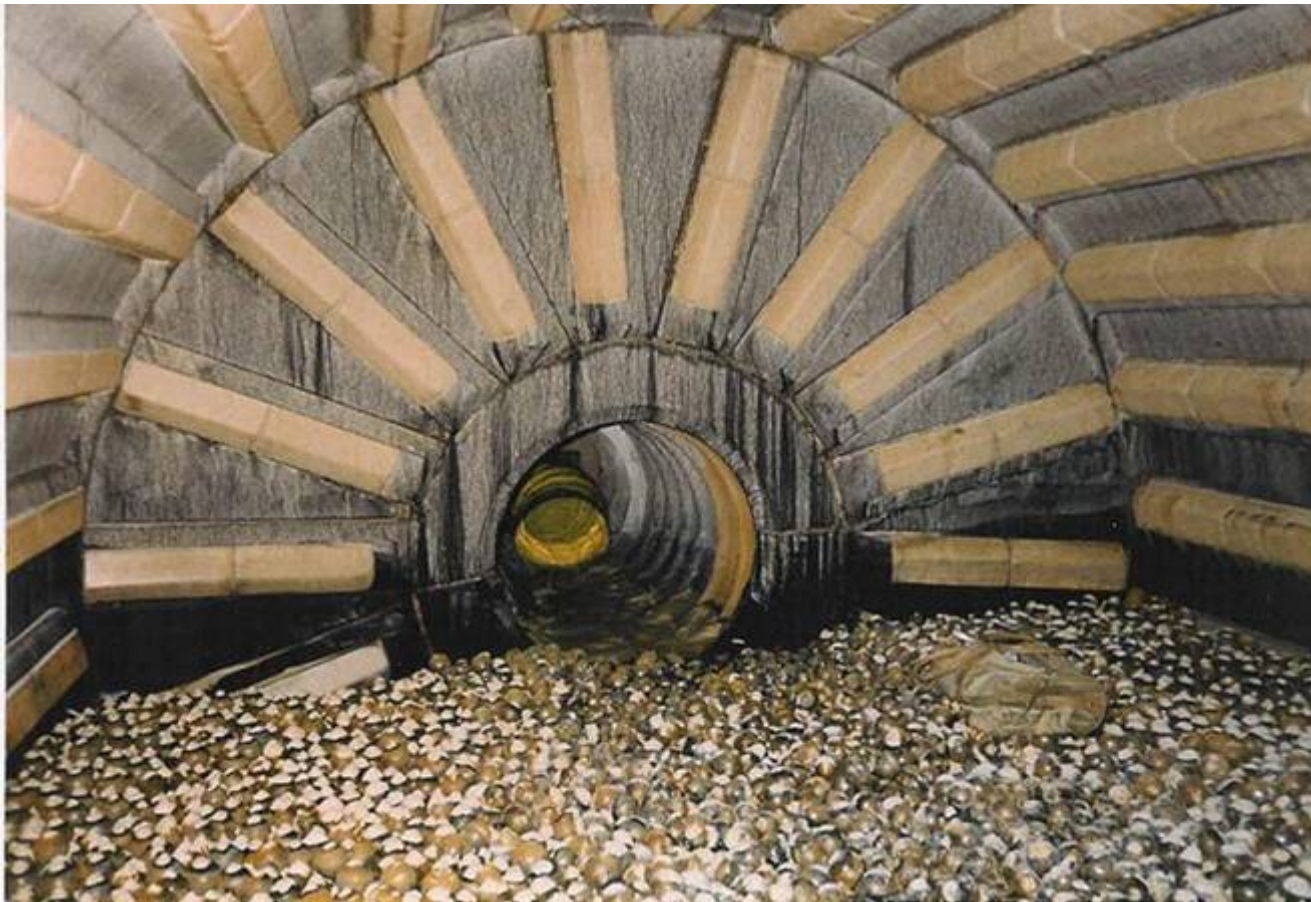

# There Are Two Things To Check First

- Do the ball mill motor amps indicate that the mill has a full ball charge.
- Is there grit in a hydrocyclone overflow line that indicates hydrocyclone puggage.



### CYCLONE CUTAWAY

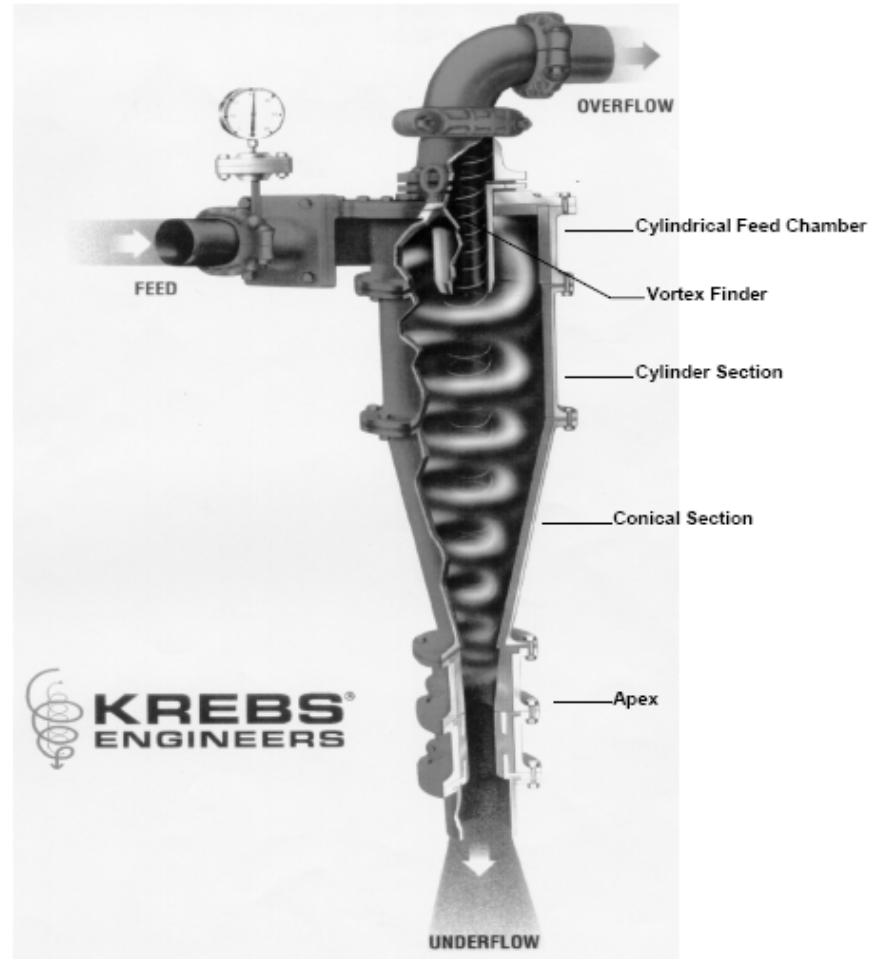



### Typical Flow Diagram for Ball Mill Limestone Grinding System

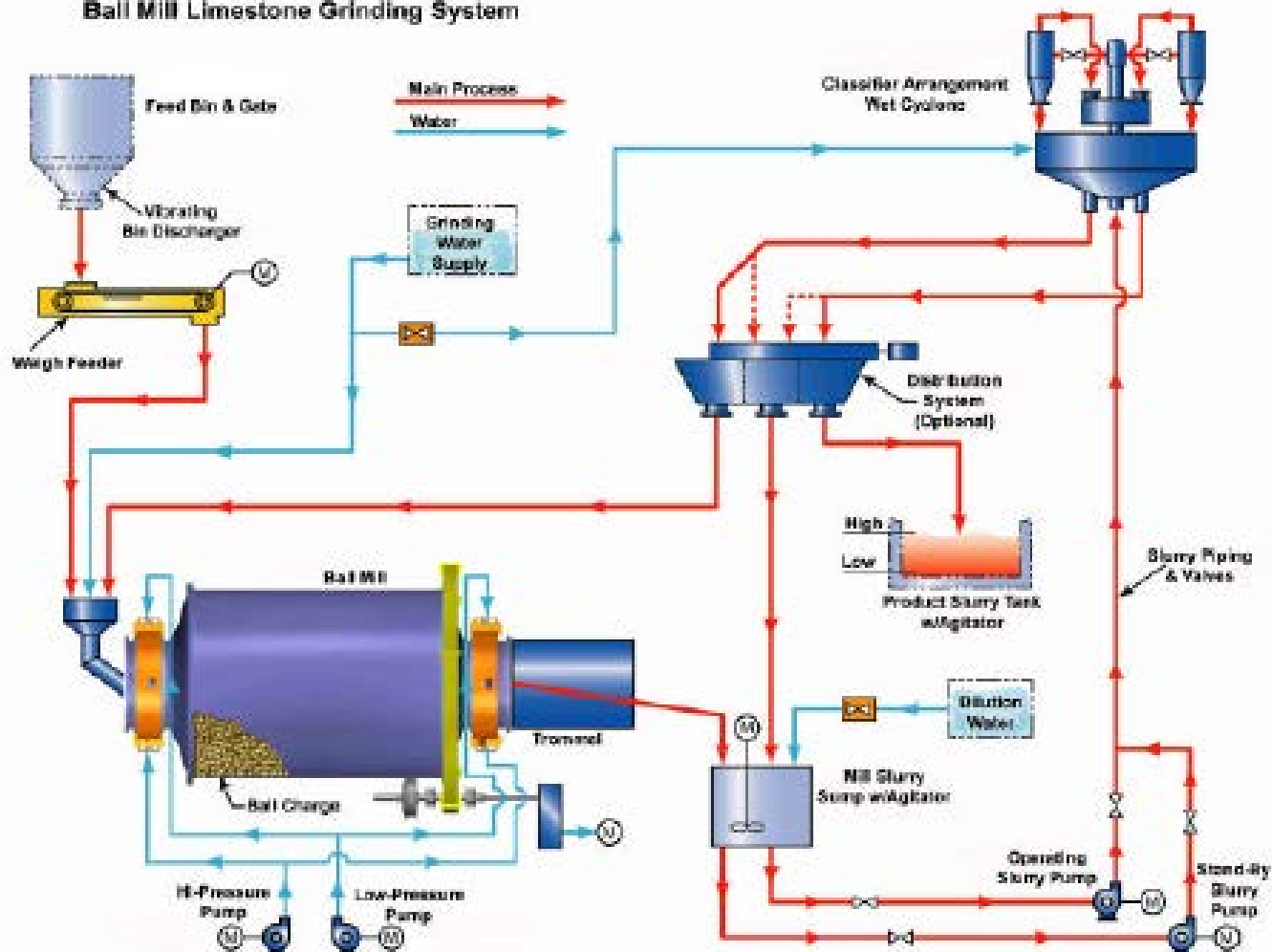

# Ball Mill Design

$$P = T \times W$$

P = Power Draw (kW) [Motor Size]

T = Limestone Feed Rate (ton/hour)

W = Work Input (kWh/ton)

# Work Input

$$W = \frac{10 W_i}{\sqrt{D_P}} - \frac{10 W_i}{\sqrt{D_F}}$$

$W_i$  = Bond Work Index (kWh/ton)

$D_P$  = Diameter of 80% of Product (microns)

$D_F$  = Diameter of 80% of Feed (microns)

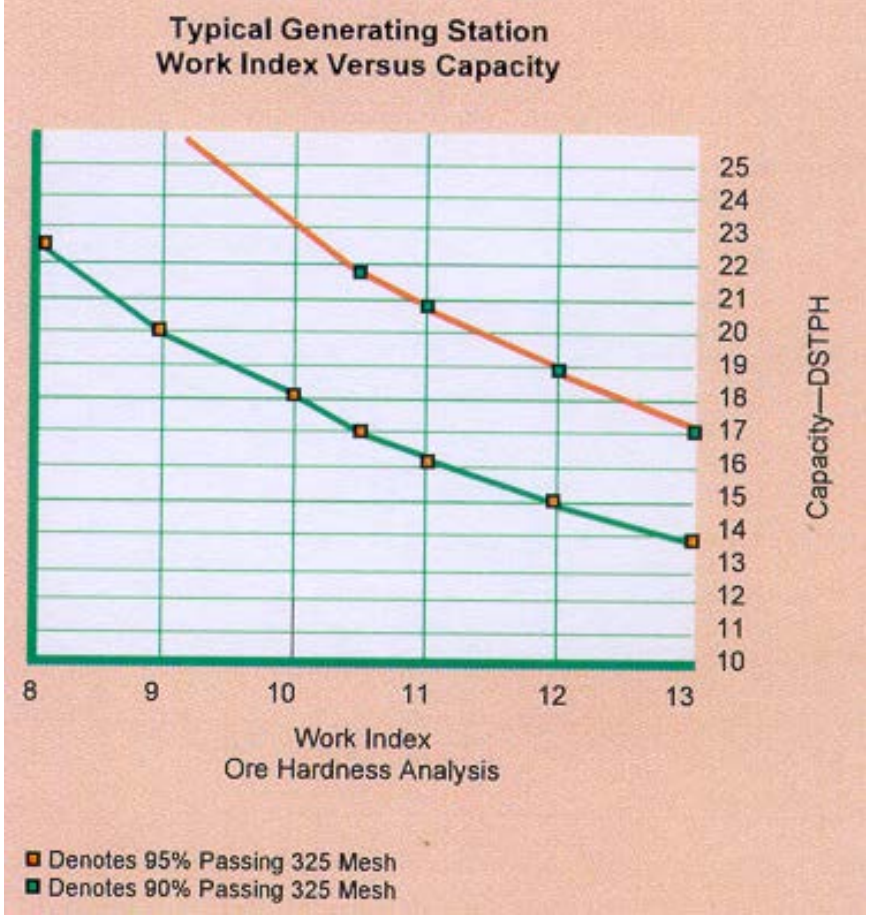
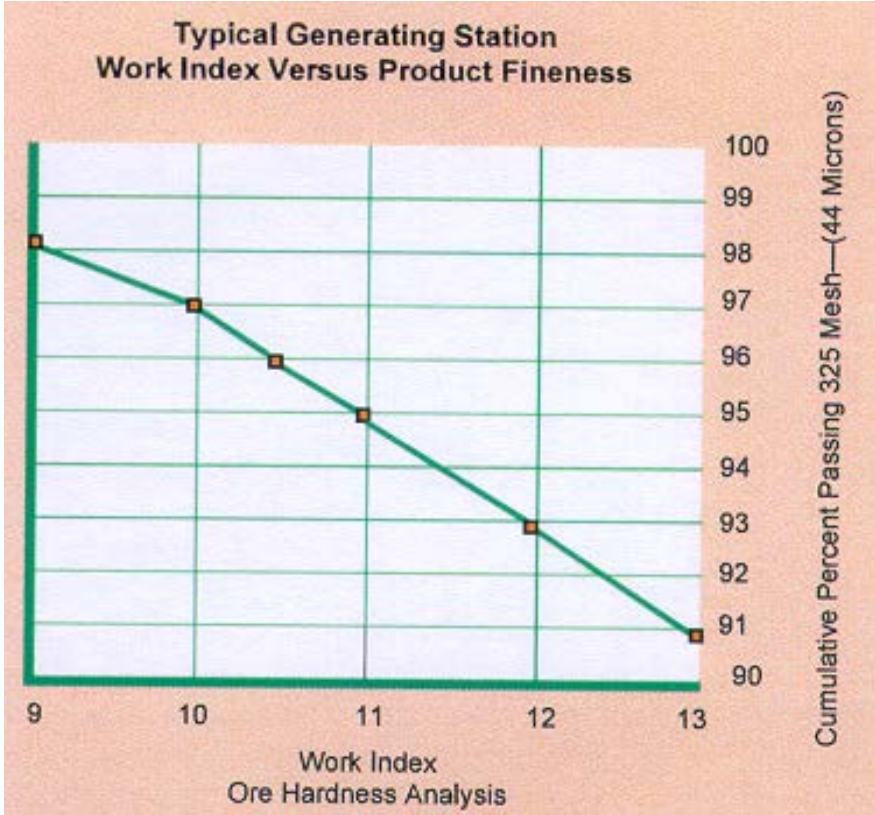

Source: METSO

# Mist Eliminators

# Achilles' Heel??

- With the current design of a large single FGD tower with no bypass, I feel that the mist eliminators may pose one of the biggest risks for a forced outage of the unit.

# The Problem – Scale Formation





# The Solution

- All FGD vendors supply a mist eliminator wash system as part of their design.

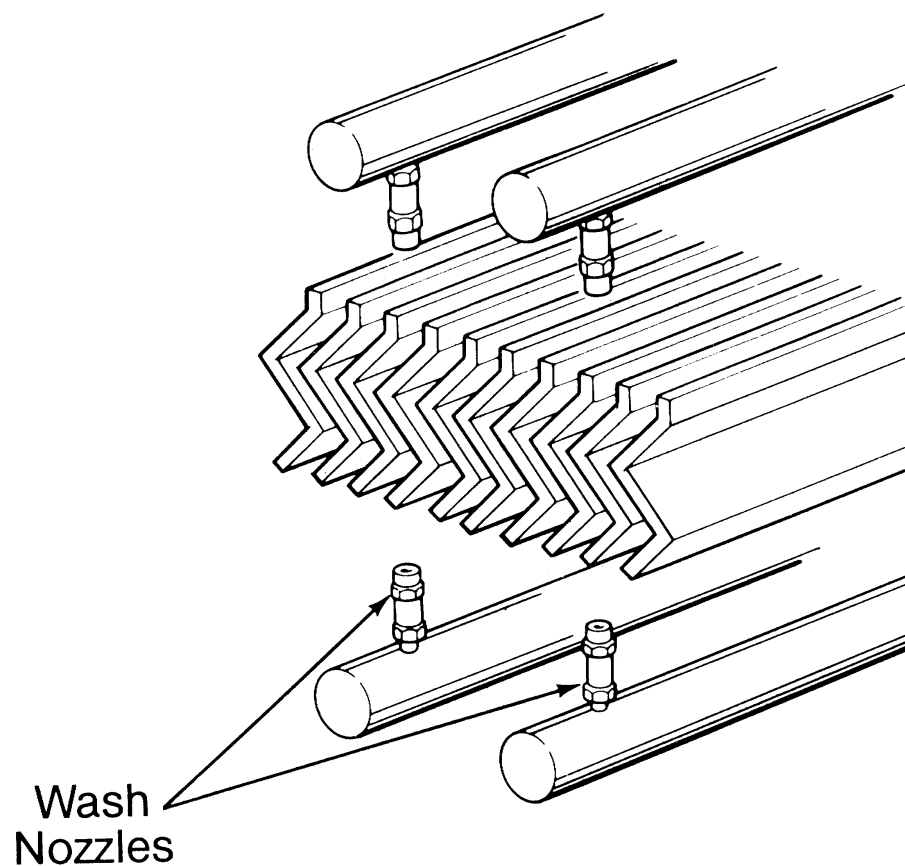

# The Only Effective Mist Eliminator Wash System



# What You Really Have

- A “keep the blades wet and the liquid collecting on them diluted below calcium saturation so scale doesn’t form” system.

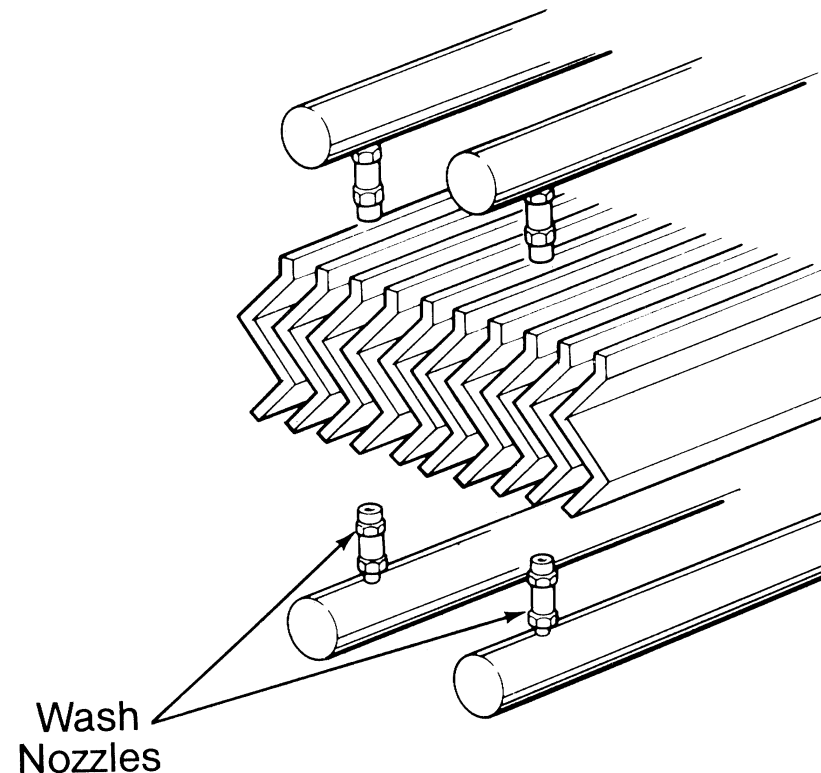

# What That Really Means

- You must constantly be in a proactive mode of keeping scale from forming on the blades rather than being in a reactive mode of trying to wash it off after it forms because you can't wash all of it off with the system you have.

# What That Means

- The wash water needs to be as fresh (unsaturated with calcium) as possible.
- Each blade needs to be washed as often as possible.
- An “in-situ forced oxidized” tower has less problems.
- Adding a scale inhibitor to the wash water may need to be considered.

# ME Wash Water

- Use as much “service water” or other fresh water as the water balance will allow.
- Add “process water” only as needed to maintain the level in the ME Wash Water Tank.

# Wash Cycles

- Most designs only wash one portion of one side of a mist eliminator at a time.
- If possible, always be washing something.



# Wash Cycles

- If the water balance will only allow you to wash each section for 8 minutes every hour:
  - **It is better to wash for 1 minute every 8 minutes**
  - **Than to wash for 2 minutes every 15 minutes**
  - **Than to wash for 4 minutes every 30 minutes**
  - **Than to wash for 8 minutes every 60 minutes**

# Wash Nozzle Considerations

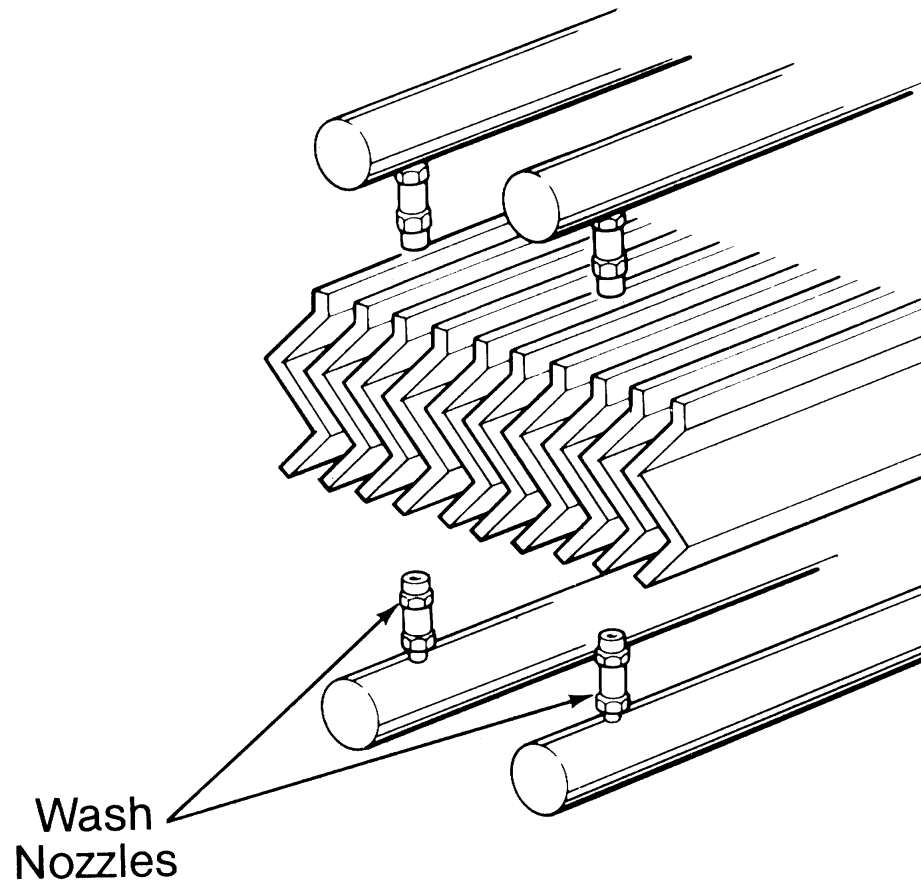

# Wash Nozzle Pattern



# Spray Pattern Angle

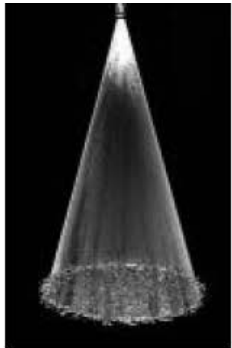

Full Cone 30° (NN)

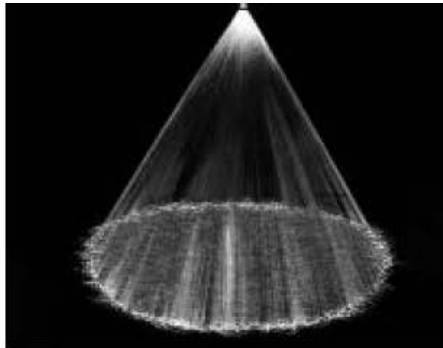

Full Cone 60° (N)

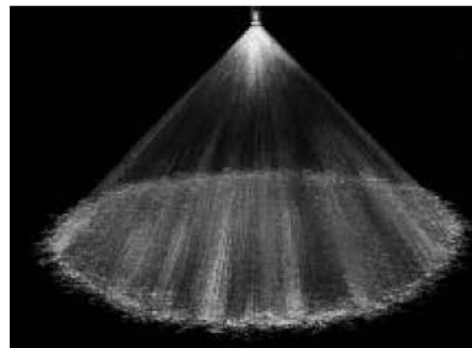

Full Cone 90° (M)

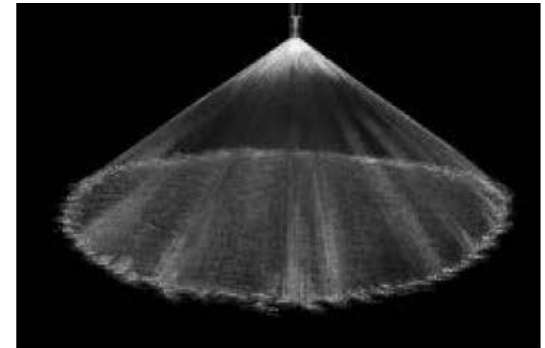

Full Cone 120° (W)

# APS Side by Side Comparison

Figure 2. Test Installation at APS's Cholla Station, Unit 2: Materials (left to right) Polysulfone, FRP, Stainless Steel, Polypropylene



Source: KOCH-Glitsch

# APS Side by Side Comparison

**Figure 3. Polypropylene mist eliminator**



**Figure 5. Stainless steel mist eliminator**



**Figure 4. FRP mist eliminator from**



**Figure 6. Polysulfone mist eliminator with polypropylene supports**

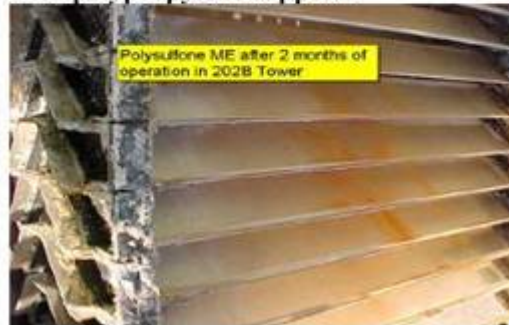

Source: KOCH-Glitsch



# Quadrant Valves Not Opening

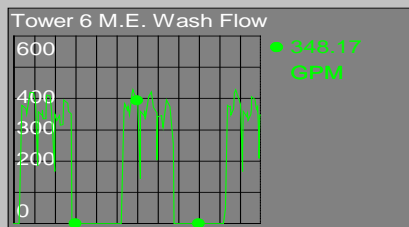
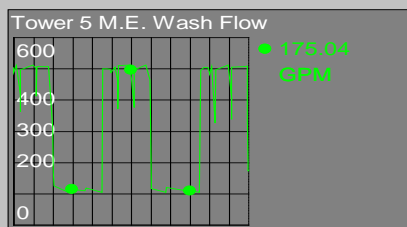
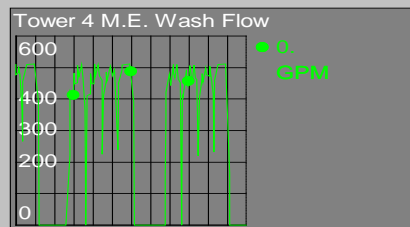
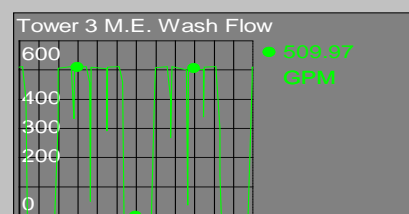
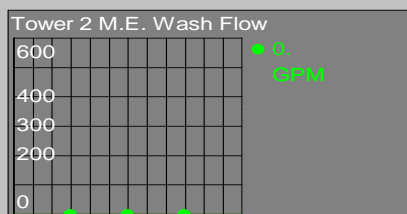
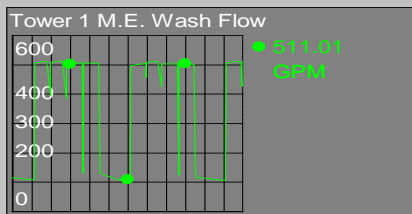



# Leaking ME Wash Valves?

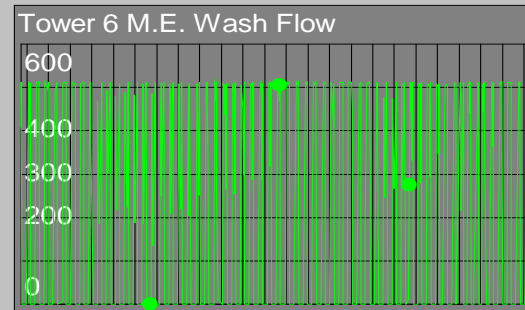
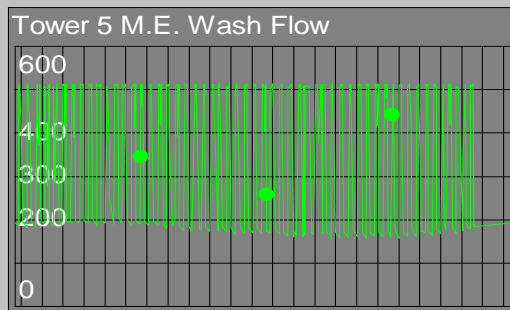
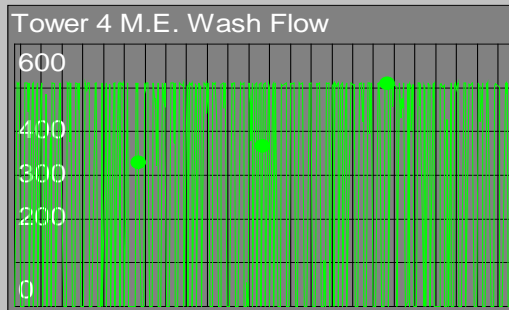
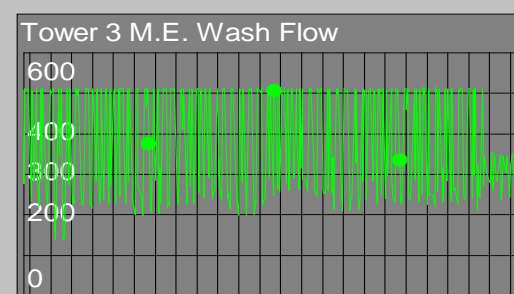
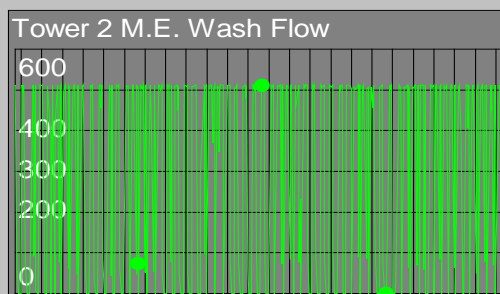
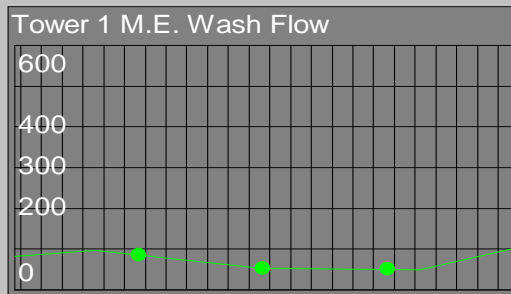

# Asiatic Clams Plugging ME Wash Pump Suction Strainer – Part 1

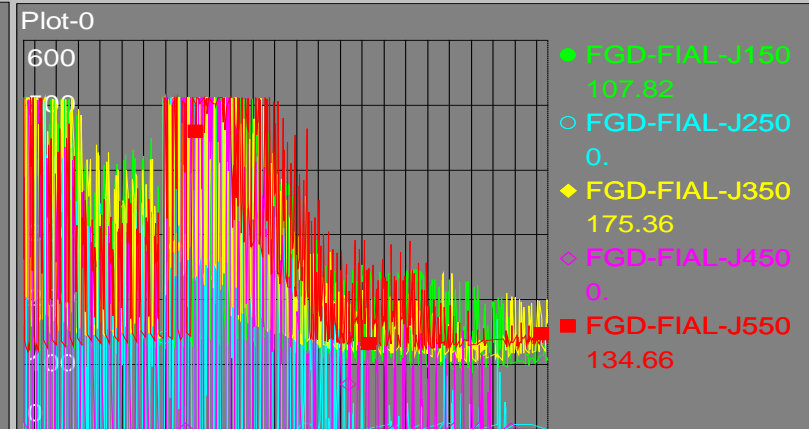
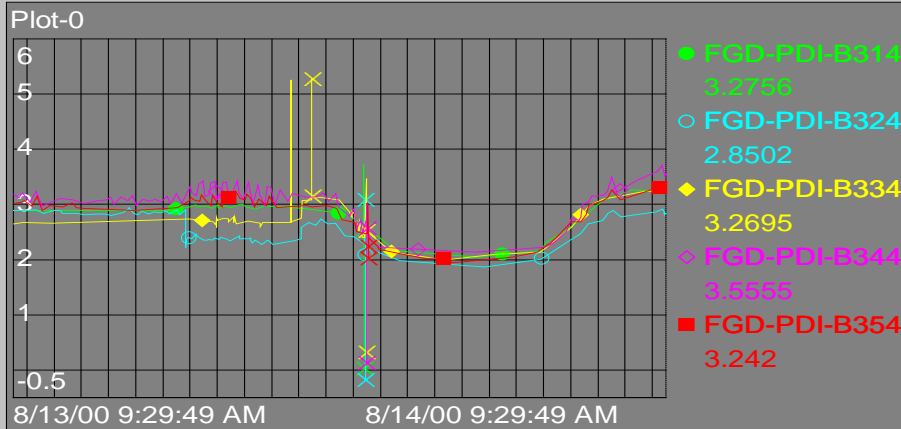

# Asiatic Clams Plugging ME Wash Pump Suction Strainer – Part 2

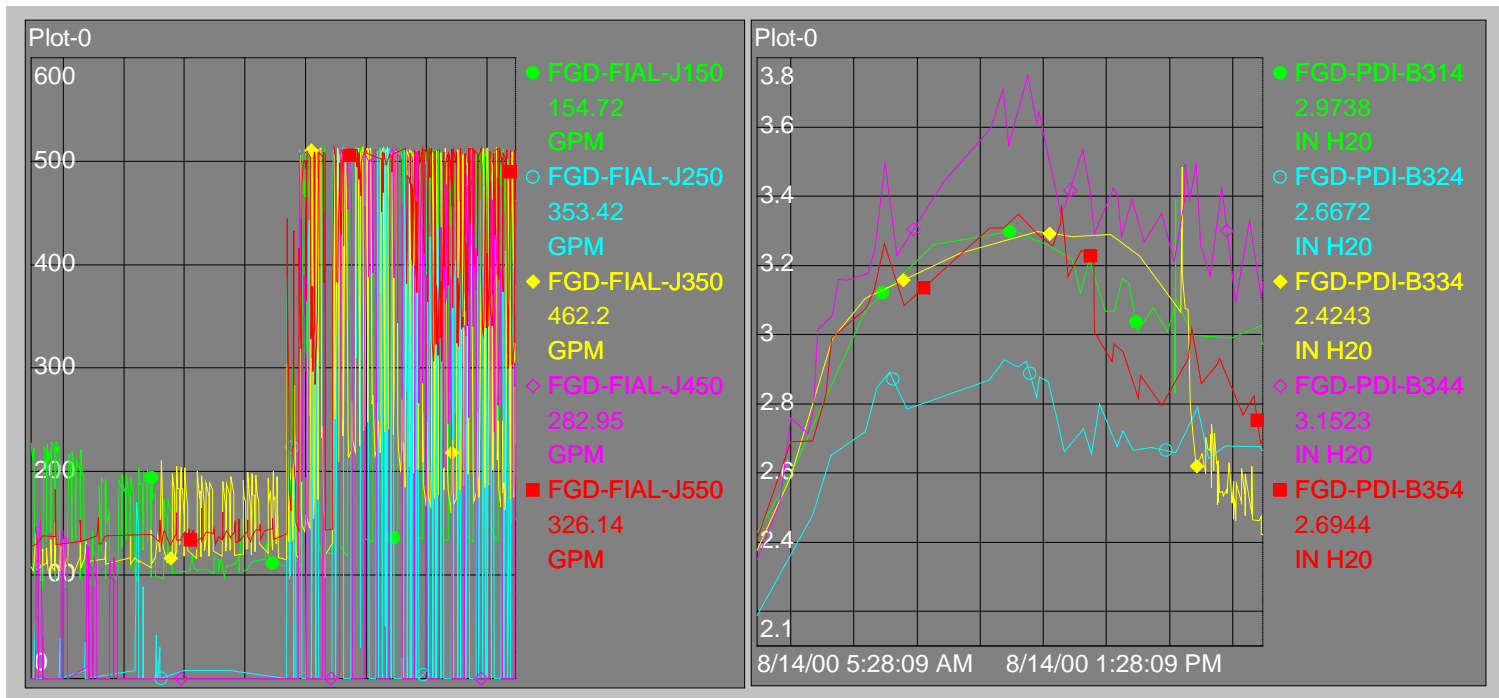

# ME Plugged 15 Days After Previous Cleaning

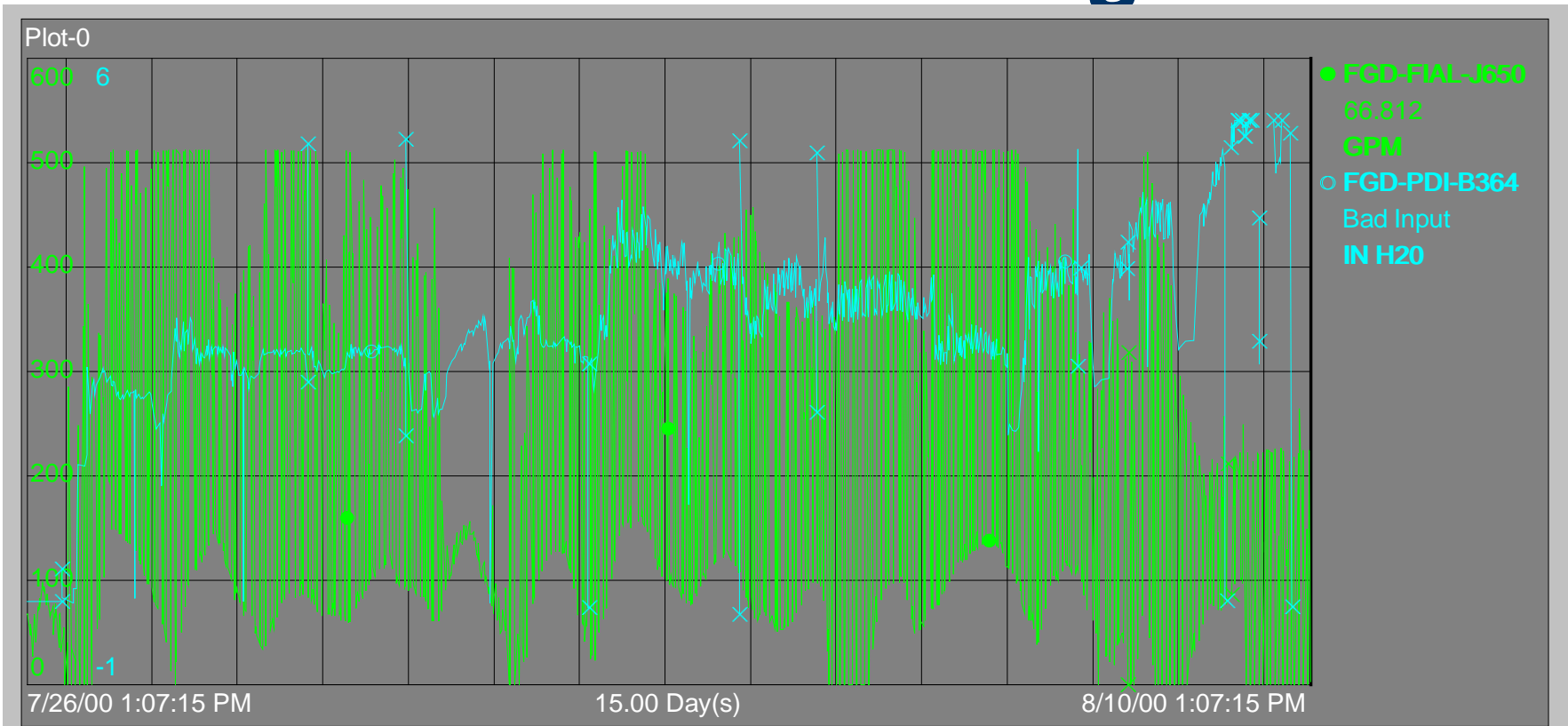

# Wash Failure Resulting In Tower Forced Outage

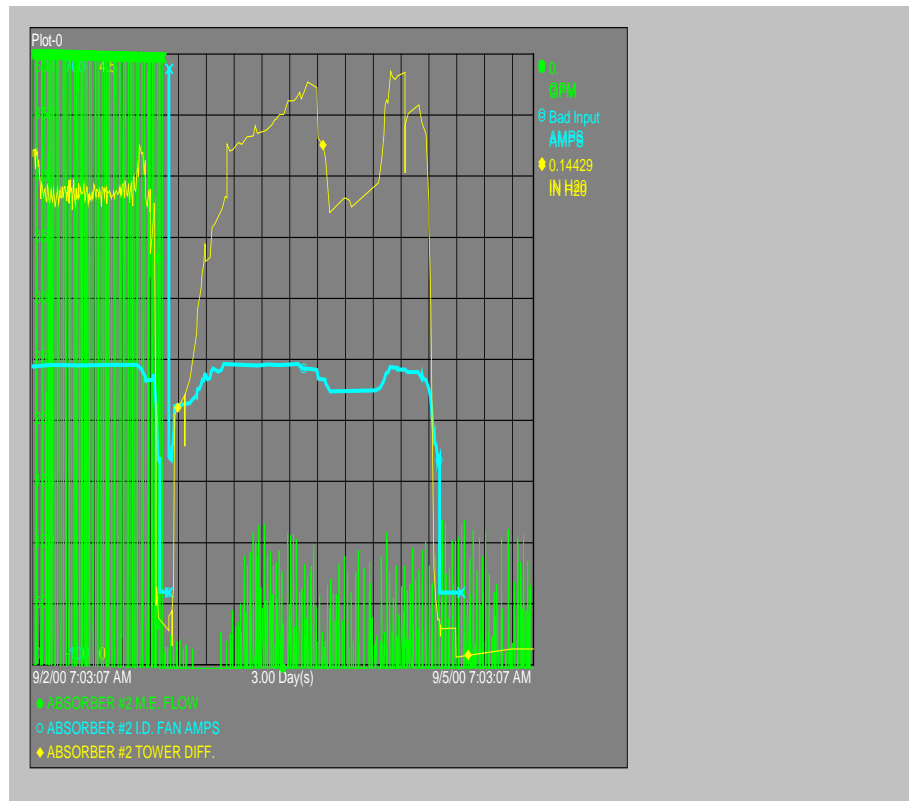

# Cleaning Effectiveness

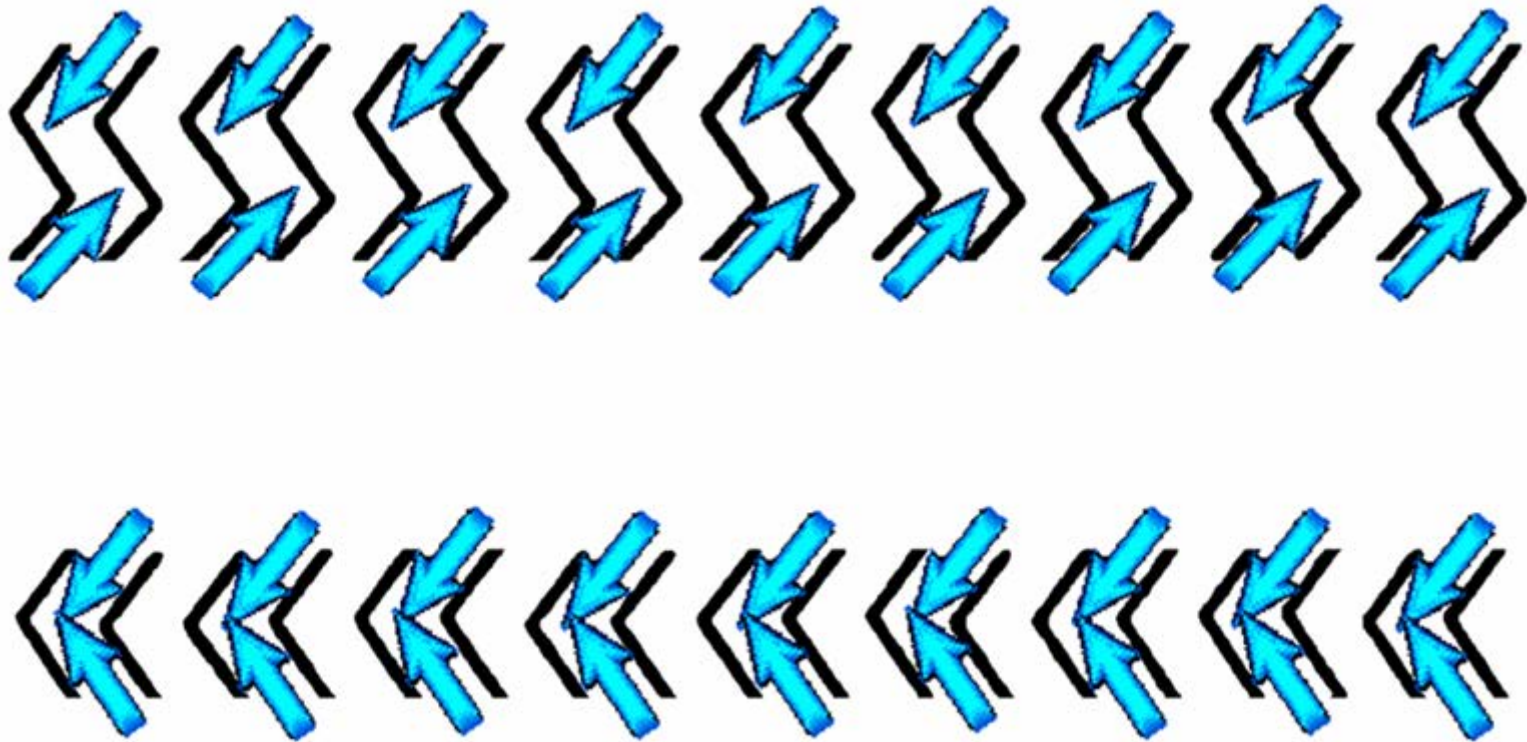

# Preventing Damage During High Pressure Washing

- Don't use any more nozzle pressure than necessary to remove the deposit.
- A fan pattern nozzle does less cutting of the blade than a straight pattern nozzle.
- Keep the nozzle several inches from the blade.
- Keep the nozzle as parallel as possible with the blades.



**I hope that something you saw here today will allow you to experience less problems with your mist eliminators.**